

CABLE THERMOCOUPLE

Type XI-TTE411, XI-TTE412

Thermocouple with threaded process connection, also available in angle construction. Universal temperature measurement of liquids, gases and solid bodies. Temperature range of the sensor depends on insulation of connection cable.

Thermocouples of this series are designed for screw-fitting directly into the process, mainly in vessels and pipelines. These thermocouples are suitable for liquid and gaseous media under moderate mechanical load and normal chemical conditions. The sensor consists of thermocouple cable, protection tube with threaded process connection and cable.

Insertion length, process connection, construction type, thermocouple type, accuracy, cable insulation can be selected individually for the respective application.

TECHNICAL DATA

Description

- Intrinsicly safe for mines M1, gas G and dust D atmospheres
- Single and double TC
- Angle version (XI-TTE411) and straight (XI-TTE412)

Temperature range

-10.. +105°C	with cable in PVC
-50.. +180°C	with cable in silicone rubber
-50.. +260°C	with cable in teflon® PFA
-50.. +400°C	with cable in fiberglass

Sensing element

1x or 2x NiCr-NiAl	K	acc. to EN 60584-2 class 1, 2
1x or 2x NiCrSi-NiSi	N	acc. to EN 60584-2 class 1, 2
1x or 2x Fe-CuNi	J	acc. to EN 60584-2 class 1, 2
1x or 2x NiCr-CuNi	E	acc. to EN 60584-2 class 1, 2
1x or 2x Cu-CuNi	T	acc. to EN 60584-2 class 1, 2

Protection tube

Material	stainless steel 1.4541*
Diameter [mm]	Ø3, Ø4, Ø5, Ø6, Ø8, Ø9*
Length L [mm]	custom

Thermocouple cable

JJ	PVC / PVC (up to +105°C)
TPSL	teflon® / Cu braid / silicone (up to +180°C)
TT	teflon® PFA / teflon® PFA (up to +260°C)
TCuT	teflon® PFA / Cu braid / teflon® PFA (up to +205°C)
GLGLP	fiberglass / fiberglass / steel braid (up to +400°C)

Remarks

*other parameters upon request

ATEX Marking:

- CE I M1 Ex ia I Ma
- CE II 1/2 G Ex ia II C T... Ga/Gb
- CE II 1/2 D Ex ia II C T... Da/Db

IECEx Marking:





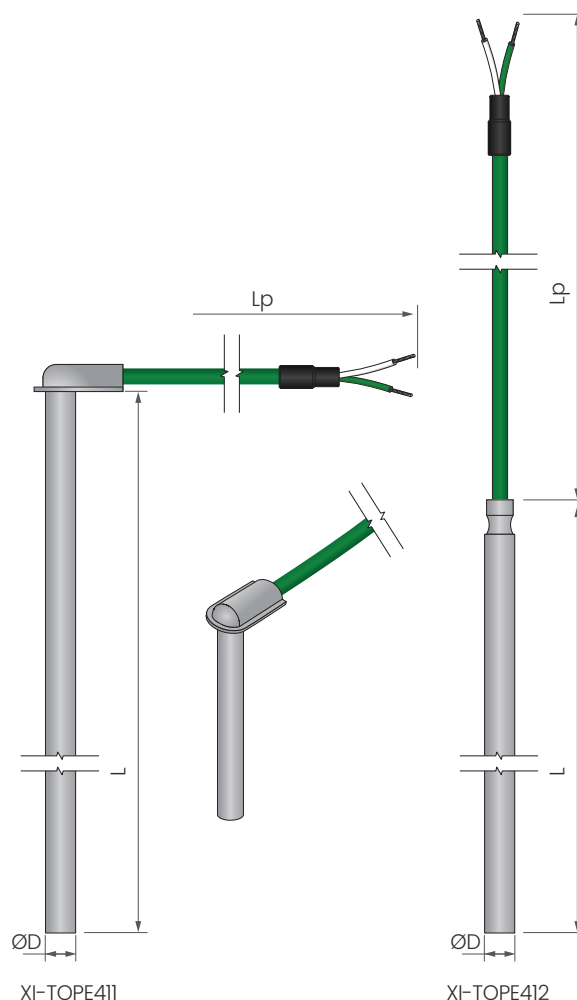

- Ex ia I Ma
- Ex ia IIC T ...Ga
- Ex ia IIIC T ...Da





EAC Ex Marking:

- PO Ex ia I Ma X
- 0Ex ia IIC T..Ga X
- 0Ex ia IIIC T..Da X



Temperature range of the sensor depends on insulation of connection cable.

Connection cable	cross	diameter	code
up to +105°C.  PVC / PVC	 2 x 0.22 mm ²	Ø4.0 Ø5.0 Ø5.0 Ø6.0	JJ-2x0.22mm ² JJ-2x0.44mm ² JJ-4x0.50mm ² JJ-2x0.75mm ²
up to +180°C.  silicone / silicone	 2 x 0.22 mm ²	Ø3.4 Ø4.5	TSL-2x0.22mm ² TSL-2x0.75mm ²
up to +400°C.  fiberglass / fiberglass / steel braid	 2 x 0.22 mm ²	Ø3.6	GLGLP-2x0.22 mm ²
 2 x 0.50 mm ² 2 x 0.50 mm ²	3x4 4x5	GLGLP-2x0.50 mm ² GLGLP-2x0.75 mm ²	

Connection cable	cross	diameter	code
up to +260°C.  teflon® PFA / teflon® PFA	 2 x 0.22 mm ² 2 x 0.50 mm ² 2 x 0.75 mm ²	1.9x2.3 1.7x3.0 2.4x4.2	TT-2x0.22mm ² TT-2x0.50mm ² TT-2x0.75mm ²
up to +205°C.  teflon® FEP/Cu braid/ teflon® FEP	 2 x 0.22 mm ² 4 x 0.22 mm ² 2 x 0.50 mm ² 4 x 0.50 mm ² 6 x 0.50 mm ² 4 x 0.75 mm ² 6 x 0.75 mm ²	Ø2.9 Ø3.6 Ø3.8 Ø4.6 Ø5.1 Ø5.1 Ø6.3	TCuT-2x0.22 mm ² TCuT-4x0.22 mm ² TCuT-2x0.50 mm ² TCuT-4x0.50 mm ² TCuT-6x0.50 mm ² TCuT-4x0.75 mm ² TCuT-6x0.75 mm ²

ORDERING CODE

Temperature sensor		XI - TTE4	①	②	③	④	⑤	⑥	⑦
version:	(angled) (straight)	11 12							
sensing element:	Type K Type J Type N Type E Type T	K J N E T							
diameter [mm]:	3, 4, 5, 6 or other*	<input type="checkbox"/>							
length L [mm]:	custom	<input type="checkbox"/>							
cable length L _p [mm]:	custom	<input type="checkbox"/>							
TC class:	1, 2	<input type="checkbox"/>							
cable insulation	(see specification)	<input type="checkbox"/>							

EXAMPLE: Temperature sensor XI-TTE411-T-5-50-2000-1-TT

① ② ③ ④ ⑤ ⑥ ⑦

Temperature sensor XI-TTE412-K-4-50-1500-1-TT

① ② ③ ④ ⑤ ⑥ ⑦