



2-wire programmable transmitter

5331A

- RTD, TC, Ohm, or mV input
- Extremely high measurement accuracy
- 1.5 kVAC galvanic isolation
- Programmable sensor error value
- For DIN form B sensor head mounting



Application

- Linearized temperature measurement with Pt100...Pt1000, Ni100...Ni1000, or TC sensor.
- Conversion of linear resistance variation to a standard analog current signal, for instance from valves or Ohmic level sensors.
- Amplification of a bipolar mV signal to a standard 4...20 mA current signal.

Technical characteristics

- Within a few seconds the user can program PR5331A to measure temperatures within all ranges defined by the norms.
- The RTD and resistance inputs have cable compensation for 2-, 3- and 4-wire connection.
- Continuous check of vital stored data for safety reasons.

Mounting / installation

- For DIN form B sensor head or DIN rail mounting with the PR fitting type 8421.

Application

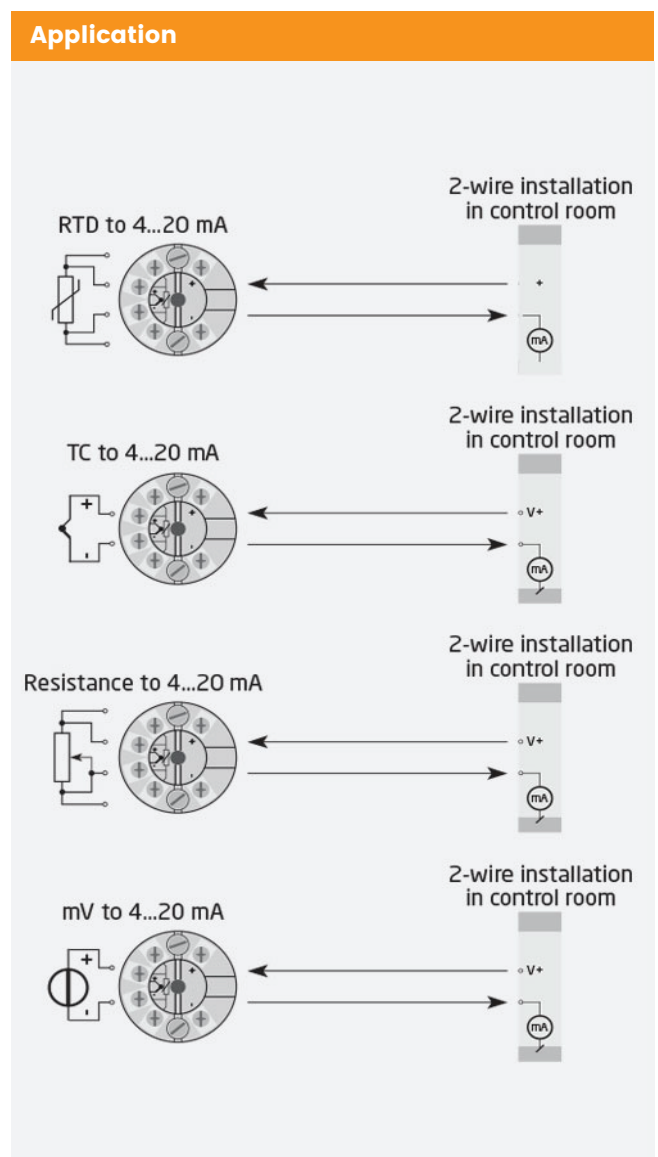

This page is automatically generated on the basis of information provided on www.prelectronics.com and affiliated websites. It is provided to you as a service and for information purpose only. While we have attempted to maintain the information as accurately as possible, the page may contain errors or omissions for which we disclaim any and all liability.

Order

Type	Version	Ambient temperature	Galvanic isolation
5331	Zone 2 / Div. 2 :A	-40°C...+85°C :3	1500 VAC :B

Environmental Conditions

Operating temperature : -40°C to +85°C
 Calibration temperature : 20...28°C
 Relative humidity : < 95% RH (non-cond.)
 Protection degree (encl./terminal) : IP68 / IP00

Mechanical specifications

Dimensions : Ø 44 x 20.2 mm
 Weight approx : 50 g
 Wire size : 1 x 1.5 mm² stranded wire
 Screw terminal torque : 0.4 Nm
 Vibration : IEC 60068-2-6
 2...25 Hz : ±1.6 mm
 25...100 Hz : ±4 g

Common specifications

Supply

Supply voltage : 7.2...35 VDC
 Internal power dissipation : 25 mW...0.8 W

Isolation voltage

Isolation voltage, test / workin : 1.5 kVAC / 50 VAC

Response time

Response time (programmable) : 1...60 s

Voltage drop : 7.2 VDC
 Warm-up time : 5 min.
 Power on to stable output : 4.5 s
 Programming : Loop Link
 Signal / noise ratio : Min. 60 dB
 EEprom error check : < 3.5 s
 Accuracy : Better than 0.05% of selected range

Signal dynamics, input : 20 bit
 Signal dynamics, output : 16 bit
 Effect of supply voltage change : < 0.005% of span / VDC
 EMC immunity influence : < ±0.5% of span
 Extended EMC immunity : NAMUR
 NE21, A criterion, burst : < ±1% of span

Input specifications

Common input specifications

Max. offset : 50% of selected max. value

RTD input

RTD type : Pt100, Ni100, lin. R
 Cable resistance per wire : 5 Ω (max.)
 Sensor current : 0.2 mA, < 0.4 mA
 Effect of sensor cable resistance (3-wire) : < 0.002 Ω / Ω
 Sensor error detection : Yes

Linear resistance input

Linear resistance min....max. : 0 Ω...5000 Ω

TC input

Thermocouple type : B, E, J, K, L, N, R, S, T, U, W3, W5, LR

Cold junction compensation (CJC) : < ±1.0°C
 Sensor error detection : Yes
 Sensor error current detecting / else. : When : Nom. 33 µA / 0 µA

Voltage input

Measurement range : -12...800 mV
 Min. measurement range (span) : 5 mV
 Input resistance. : 10 MΩ

Output specifications

Current output

Signal range : 4...20 mA
 Min. signal range : 16 mA
 Load (@ current output) : ≤ (Vsupply - 7.2) / 0.023 [Ω]
 Load stability : ≤ 0.01% of span / 100 Ω
 Sensor error indication : Programmable 3.5...23 mA
 NAMUR NE43 Upscale/Downscale : 23 mA / 3.5 mA

Common output specifications

Updating time of span : 440 ms
 of span : = of the presently selected range

I.S. / Ex marking

ATEX : II 3 G Ex nA [ic] IIC T6...T4 Gc, II 3 G Ex ec [ic] IIC T6...T4 Gc, II 3 G Ex ic IIC T6...T4 Gc, II 3 D Ex ic IIIC Dc
 IECEx : Ex nA [ic] IIC T6...T4 Gc, Ex ec [ic] IIC T6...T4 Gc, Ex ic IIC T6...T4 Gc, Ex ic IIIC Dc
 CSA : Cl. I, Div. 2, Gp. A, B, C, D T6...T4, Ex nA [ic] IIC T6...T4 Gc
 INMETRO : Ex nA [ic] IIC T6...T4 Gc, Ex ic IIC T6...T4 Gc, Ex ic IIIC Dc

Observed authority requirements

EMC : 2014/30/EU & UK SI 2016/1091
 ATEX : 2014/34/EU & UK SI 2016/1107
 RoHS : 2011/65/EU & UK SI 2012/3032
 EAC : TR-CU 020/2011
 EAC Ex : TR-CU 012/2011

Approvals

ATEX : DEKRA 20ATEX0096X
 IECEx : DEK 20.0059X
 CSA : I125003
 INMETRO : DEKRA 16.0013 X
 DNV Marine : TAA0000101
 EAC Ex : RU C-DK.HA65.B.00355/19