

Pt100 converter, loop-powered

3333

- High accuracy, better than 0.1% of span
- Slimline housing of 6.1 mm
- Excellent EMC performance and 50/60 Hz noise suppression
- Selectable < 30 ms / 300 ms response time
- Pre-calibrated temperature ranges selectable via DIP-switches



Application

- The 3333 temperature converter measures a standard 2-, 3- or 4-wire Pt100 temperature sensor, and provides a passive analog current output signal.
- The 3333 can be mounted in the safe area or in Zone 2 / Division 2 areas.
- Approved for marine applications.

Technical characteristics

- Flexibly loop powered by 3.3...35 VDC via connectors. < 30 ms fast response time with simultaneous sensor error detection when selected.
- Selectable 300 ms response time when signal dampening is needed.
- High conversion accuracy in all available ranges, better than 0.1% of span.
- Meeting the NAMUR NE21 recommendations, the 3333 provides top measurement performance in harsh EMC environments.
- The device meets the NAMUR NE43 standard defining out of range and sensor error output values.
- All terminals are protected against overvoltage and polarity error.
- Excellent signal/noise ratio of > 60 dB.

Mounting / installation

- Selectable DIP-settings for easy configuration of more than 1000 factory calibrated measurement ranges.
- The narrow 6.1 mm housing allows up to 165 units to be mounted per meter of DIN rail, without any air gap between units.
- Wide ambient temperature range of -25...+70°C.

Application

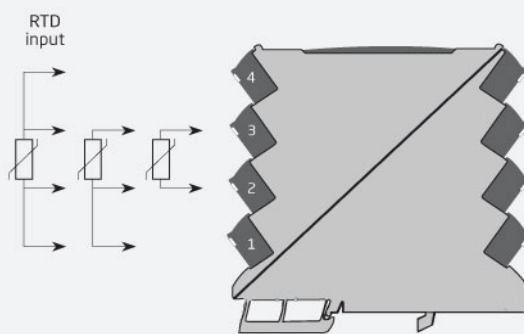

**Safe Area or
Zone 2 & Cl. 1, Div. 2, gr. A-D**

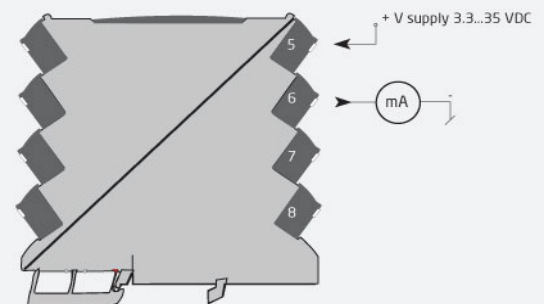

Order

Type
3333

Environmental Conditions

Operating temperature	: -25°C to +70°C
Storage temperature	: -40°C to +85°C
Calibration temperature	: 20...28°C
Relative humidity	: < 95% RH (non-cond.)
Protection degree	: IP20
Installation in	: Pollution degree 2 & meas. / overvoltage cat. II

Mechanical specifications

Dimensions (HxWxD)	: 113 x 6.1 x 115 mm
Weight approx	: 70 g
DIN rail type	: DIN EN 60715/35 mm
Wire size	: 0.13...2.5 mm ² / AWG 26...12 stranded wire
Screw terminal torque	: 0.5 Nm
Vibration	: IEC 60068-2-6
2...25 Hz	: ±1.6 mm
25...100 Hz	: ±4 g

Common specifications

Supply

Supply voltage	: 3.3...35 VDC
Max. required power	: 0.80 W
Internal power dissipation	: 12 mW...0.8 W

Response time

Response time (0...90%, 100...10%)	: < 30 ms / 300 ms (selectable)
Voltage drop	: 3.3 VDC
Signal / noise ratio	: Min. 60 dB
Programming	: DIP-switches
Signal dynamics, input	: 23 bit
Signal dynamics, output	: 18 bit
EMC immunity influence	: < ±0.5% of span
Extended EMC immunity: NAMUR NE21, A criterion, burst	: < ±1% of span
Incorrect DIP-switch setting identification	: 3.5 mA

Input specifications

RTD input

Temperature range, Pt100	: -200...+850°C
Min. measurement range (span)	: 10°C
Accuracy: the greater of	: Better than 0.05% of span or 0.1°C
Temperature coefficient: the greater of	: 0.02°C/°C or ≤ ±0.01%/°C
Sensor current	: < 150 µA
Sensor cable resistance	: < 50 Ω per wire
Effect of sensor cable resistance (3-/4-wire)	: < 0.002 Ω / Ω
Sensor error detection	: Yes - selectable via DIPswitch
Broken sensor detection	: > 800 Ω
Shorted sensor detection	: < 18 Ω

Output specifications

Common output specifications

Updating time	: 10 ms
Current output	
Programmable signal ranges	: 4...20 and 20...4 mA
Load (@ current output)	: ≤ (Vsupply - 5.5) / 0.023 [Ω]
Load stability	: ≤ 0.01% of span / 100 Ω
Sensor error indication	: 3.5 mA or 23 mA / acc. to NAMUR NE43 or OFF

I.S. / Ex marking

ATEX	: II 3 G Ex ec IIC T4 Gc
IECEx	: Ex ec IIC T4 Gc
FM, US	: Cl. I, Div. 2, Gp. A, B, C, D T4 or Cl. I, Zone 2, AEx nA IIC T4
FM, CA	: Cl. I, Div. 2, Gp. A, B, C, D T4 or Cl. I, Zone 2, Ex nA IIC T4
EAC Ex	: 2Ex nA IIC T4 Gc X

Observed authority requirements

EMC	: 2014/30/EU & UK SI 2016/1091
LVD	: 2014/35/EU & UK SI 2016/1101
ATEX	: 2014/34/EU & UK SI 2016/1107
RoHS	: 2011/65/EU & UK SI 2012/3032
EAC	: TR-CU 020/2011
EAC Ex	: TR-CU 012/2011

Approvals

ATE	: KEMA 10ATEX0147 X
IECEx	: KEM 10.0068X
UKEX	: DEKRA 21UKEX0055X
c FM us	: FMI7US0004X / FMI7CA0003X
c UL us, UL 61010-1	: E314307
EAC Ex	: RU C-DK.HA65.B.00355/19
DNV Marine	: TAA00001RW